Hollow

SOFAS

2006

Patricia Urquiola



Description

This project is the result of a group of modular panels of different sizes, which can be assembled through hinges to act as back and armrest and hold a soft seats. Blocked and supported by the legs, the entirely upholstered and lined panels display a concave plastic surface on the outside, which visually moves the elements and enhances their effect of lightness. The types originated from this system include a small two-seater sofa in two different sizes and a small three-seater sofa in two different sizes. The height of the feet from ground is 30 cm (11 3/4").

Technical information

Internal frame

tubular steel and steel profiles

Internal frame upholstery

flexible cold shaped polyurethane foam, polyester fibre cover

Shell

plastic material or plastic material and leather

Feet and joints

steel

Ferrules

thermoplastic material

Cover

fabric or leather in limited categories

Technical drawings

HO136

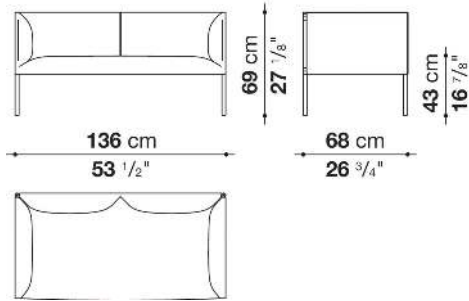

HO154

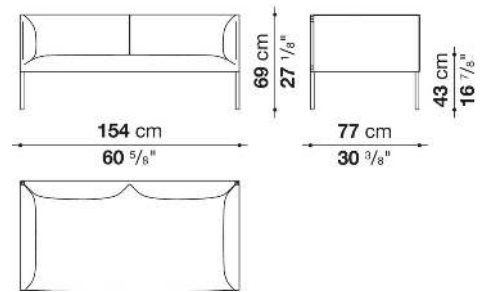

HO202

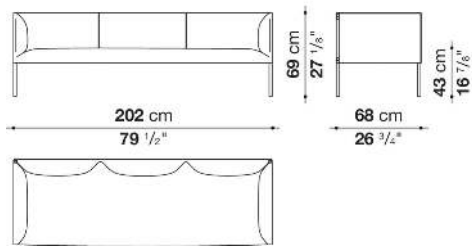

HO230

